UNIT 7 MARRIAGE AND ITS CHANGING PATTERNS

Structure

- 7.0 Objectives
- 7.1 Introduction
- 7.2 Universality of the Institution of Marriage in India
- 7.3 Age at Marriage in India
 - 7.3.1 Low Age at Marriage
 - 7.3.2 Rise in the Age at Marriage
- 7.4 Forms of Marriage
 - 7.4.1 Monogamy, Polygyny, Polyandry
 - 7.4.2 Prevailing Patterns
- 7.5 Patterns of Selection of Spouse
 - 7.5.1 Endogamy including the Rule of Hypergamy
 - 7.5.2 Exogamy
 - 7.5.3 Arranged Marriages
 - 7.5.4 Recent Trends
- 7.6 Marriage Rites
 - 7.6.1 Basic Rites of Marriage in Different Communities
 - 7.6.2 Customary Marriages
- 7.7 Transfer of Wealth and Prestige that Accompany Marriage
 - 7.7.1 Bride-Price
 - 7.7.2 Practice of Dowry
- 7.8 Divorce and Widow Remarriage
- 7.9 Let Us Sum Up
- 7.10 Keywords
- 7.11 Further Reading
- 7.12 Specimen Answers to Check Your Progress

7.0 OBJECTIVES

This unit aims to analyse the major features of the institution of marriage in India. After going through this unit you should be able to

- explain the universality of the institution of marriage in India
- discuss the aspect of age at marriage
- examine the different forms of marriage
- describe variations in the pattern of selection of spouse
- describe the basic rites of marriage in different communities
- outline how in different groups different kinds of material and symbolic transfer of wealth and prestige accompany marriage
- examine the possibilities and mechanisms for divorce and widow remarriage.

7.1 INTRODUCTION

In Block I, you were introduced to the elements of unity and diversity in Indian social structure. You were told that though certain institutions like family, marriage and kinship are universal in India, there are variations in these institutions based on region, religion, language, caste, class and occupation. That is why it is difficult to make generalisation about the institutions of Indian social structure.

Keeping this observation in mind unit 6 of this Block introduced you to the various aspects of the institution of family. Unit 7 focuses on certain salient features of marriage that help us to see the common as well as different elements in the institution of marriage in India. Section 7.2 deals with the feature of universality of the institution of marriage. Age at marriage in India is discussed in section 7.3. Thus sections 7.2 and 7.3 bring out the unity that exists, across India, relating to these two features of marriage. The features discussed in the context of diversity are the forms of marriage (section 7.4), patterns of selection of spouse (section 7.5), **rites** of marriage (section 7.6), material and non-material transactions involved in marriage (section 7.7), and the possibilities and mechanisms of divorce and widow remarriage in India (section 7.8). Most of these features relate to a man or a woman's primary marriage (i.e. marriage for the first time). Secondary marriage of a widow or a separated or divorced woman is accompanied by a nominal ceremony, where there are no or little rites. Similarly, pattern of selection of spouse may differ in a primary and a secondary marriage.

In the course of discussion of each of these aspects we shall talk of the changing patterns of marriage with particular reference to the changes that have taken place since Independence. We will discuss each aspect of marriage with suitable illustrations from some of the major communities like the Hindus, the Muslims and the Christians. Except for passing references, patterns of marriage that are found among the tribal population have not been described mainly because there is a separate Block in this Course on tribal population.

7.2 UNIVERSALITY OF THE INSTITUTION OF MARRIAGE IN INDIA

Marriage is an important social institution. It is a relationship, which is socially approved. The relationship is defined and sanctioned by custom and law. The definition of the relationship includes not only guidelines for behaviour relating to sex but also regarding things like the particular way labour is to be divided and other duties and privileges. Children born of marriage are considered the legitimate offspring of the married couple. This legitimacy is important in the matter of inheritance and succession. Thus marriage is not only a means of sexual gratification but also a set of cultural mechanisms to ensure the continuation of the family. It is more or less a universal social institution in India.

The religious texts of many communities in India have outlined the purpose, rights and duties involved in marriage. Among the Hindus, for instance, marriage is regarded as a socio-religious duty. Ancient Hindu texts point out three main aims of marriage. These are *dharma* (duty), *praja* (progeny) and *rati* (sensual pleasure). That is to say that marriage is significant from both the societal as well as the individual's point of view. Marriage is significant in that it provides children especially

sons who would not only carry on the family name but also perform periodic rituals including the annual “*shraddha*” to propitiate the dead ancestors. Majority of the Hindus look upon son(s) as a support in old age to parents and as the most important source of economic enrichment to the family. Marriage, in the Hindu system, enables a man to enter into the stage of a householder. Both a man and a woman are regarded incomplete without marriage.

Even among other communities in India, marriage is regarded as an essential obligation. Islam looks upon marriage as “*sunnah*” (an obligation) which must be fulfilled by every Muslim. Christianity holds marriage as crucial to life and lays emphasis on the establishment of a mutual relationship between husband and wife and on their duty to each other.

The significance attached to marriage is reflected in the fact that only a very small percentage of men and women remain unmarried. The Report of the Committee on the Status of Women in India (CSWI 1974: 81) has indicated that only 0.5 percent of women never marry in India. By and large girls are brought up to believe that marriage is a woman’s destiny; married state is desirable and motherhood is a cherished achievement. Only a very small percentage of men and women remain unmarried by choice.

Today, marriage is still considered important and necessary, and only few individuals remain unmarried by choice. Goals of marriage are, however, undergoing changes especially for the urban and educated sections of the population. The older notions regarding large size family, (i.e., large number of children especially sons being the source of status for parents) are being replaced by preference for small size family. Marriage for self-fulfillment rather than primarily for procreation or societal welfare is also becoming prevalent.

7.3 AGE AT MARRIAGE IN INDIA

Apart from marriage being universal, early marriage is also common in India. Though there are differences between various religious groups, classes and castes in the matter of age at marriage, the median age at marriage is low in India. As early as the 18th and nineteenth century, efforts have been made to curb infant or child marriage. Reformers like Raja Rammohun Roy, Ishwar Chandra Vidyasagar, Jyotiba Phule and others in the nineteenth and early twentieth century opposed child marriage. In 1929, the Child Marriage Restraint Act was passed (popularly known as the Sarda Act) and the minimum age for marriage for girls and boys was fixed at 14 years and 17 years respectively. The Act was made applicable to all Indians. The latest amendment (in 1978) has raised the minimum age for marriage for boys and girls to 18 years and 21 years, respectively. Though the age at marriage of females in India has been rising slowly since around the middle of the twentieth century; the level at the end of the twentieth century was low in comparison to the most of the low fertility countries (Das and Dey 1998: 92).

7.3.1 Low Age at Marriage

In spite of legislations, and governmental and non-governmental efforts to educate the people about the dangers of early marriage, age at marriage is low in India. The 1971 Census data on marital status of women indicate that the average age of marriage for girls in more than one-third of the total number of districts in our

country was below 15 years (Ghosh 1984: 5). The mean age at marriage for females for the year 1991 was 18.3. The female age at marriage was lowest in Rajasthan (17.5) followed by states of Madhya Pradesh and Bihar (17.6 and 17.8 respectively) and it was highest in Kerala (22.3) followed by Assam and Punjab (21.1 and 21.0 respectively) (Census report 1991). In newspapers and journals we read about marriage melas, specially in rural areas, in which the average age of the bride is reported to be below fifteen years. In some states like Orissa, Madhya Pradesh, Uttar Pradesh and Rajasthan, child marriages continue (National Perspective Plan 1988).

Low age at marriage is related with the near universality of marriage in India. Marriage is regarded essential and thought of a girl's marriage is entertained right from her childhood. In some regions, the existence of clear-cut expectations, preferences, and rules regarding choice of a marriage partner also lead to early marriage. The desire and concern to preserve the chastity or purity of women is yet another factor. In fact, till the 1920's among certain upper castes, pre-puberty marriages were not only popular but also mandatory. There is the belief that the onset of puberty is the right age for marriage for a girl as she is then ready for maternity. This is also another important factor leading to early marriage (CSWI: 1974).

7.3.2 Rise in the Age at Marriage

Female age at marriage rose from 16.1 years in 1961 to 19.3 in 1991. The rural urban gap in female age at marriage for 1991 is 2 years and this indicates that in spite of rise in age at marriage a wide gap persists between the rural and urban areas of the country (Das and Dey 1998: 109). It is important to point out on the basis of growing evidence that age at marriage has not been low for all communities in India. For instance, among many of the hill tribes in India the average age at marriage has been above 15 years for girls. Also among the Christians, Parsis and some educated sections living in urban areas, the age at marriage has been above the minimum age prescribed by law.

You may ask what have been some of the factors that have helped in raising the age at marriage among certain sections of the population. Research (CSWI 1974: 82) suggests that in urban areas and for the well to do in rural areas education and the need for employment of boys have raised the age of marriage. In states where the literacy rate is high, age at marriage is also much higher than in those states where literacy level is low.

While, it is encouraging to note that education has helped in raising the age at marriage, it has however led to some unintended consequences. Education combined with increasing demands for dowry have led to a rise in the age at marriage. Educated girls seek educated boys and the price (dowry) of an educated groom in the 'marriage market' is high. Since most marriages in India are arranged, parents arrange a marriage only when they meet the dowry demands. Thus, necessarily the marriages of the girls are postponed and age at marriage increases. We will talk about dowry in section 7.7.2. In the next section we discuss diverse features of marriage in India and take up first the forms of marriage.

Activity 1

Talk to married persons (they could be from your family or neighbourhood) on the following aspects of marriage. Note down their age, educational qualifications and religion before you ask them these questions.

- i) Has any one in your family remained unmarried after the age of 35? If, yes, what are the reasons for this?
- ii) At what age did you get married?

Relate your answers to what has been discussed in the unit, and find out if the person remained unmarried by choice or by necessity. That is to say he/she has taken a voluntary decision to remain single. Or, the person has remained unmarried because of reasons like physical defects, poor economic status of the family or dowry etc. Secondly if he/she married at an age which was beyond the minimum legal age at marriage. Compare your answers with those given by other students at your study center.

7.4 FORMS OF MARRIAGE

All the commonly listed forms of marriage, namely, **monogamy** (marriage of a man to a woman at a time), and polygamy (marriage of a man or woman to more than one spouse) are found in India. The latter, that is polygamy, has two forms, namely, **polygyny** (marriage of a man to several women at a time) and **polyandry** (marriage of a woman to several men at a time). In ancient texts of the Hindus we find references to eight forms of marriage. For details see unit 15 on Hindu Social Organisation in Block 4. These forms reflect more on the methods by which a spouse is acquired than the number of spouses one could have at a time.

7.4.1 Monogamy, Polygyny, Polyandry

In this section, we shall focus only on monogamy, and both forms of polygamy. With regard to the prevalence of these three forms, one has to distinguish between what is permitted and what is practised by different sections of the population through time.

- i) **Monogamy:** Among the Hindus, until the passing of the Hindu Marriage Act of 1955, a Hindu man was permitted to marry more than one woman at a time. Although permitted, polygyny has not been common among the Hindus. Only limited sections of the population like kings, chieftains, headmen of villages, members of the landed aristocracy actually practised polygyny.

We may say that those who had the means and the power to acquire more than one wife at a time were polygynous. The other important reasons for polygyny were the barrenness of the wife and or her prolonged sickness. Among some occupational groups like the agriculturists and artisans, polygyny prevailed because of an economic gain involved in it. Where women are self-supporting and contribute substantially to the productive activity a man can gain by having more than one wife.

Concerted efforts to remove this practice were made in the nineteenth century and early twentieth century by social reformers like Raja Rammohun Roy,

Ishwar Chandra Vidyasagar, Dayanand Saraswati and others. After Independence, the Hindu Marriage Act of 1955 established monogamy for all Hindus and others who came to be governed by this Act. Some of the 'other' communities covered by this Act are the Sikhs, Jains and Buddhists. Strict monogamy is prescribed in Christian and Parsi communities.

- ii) **Polygyny:** Islam, on the other hand, has allowed polygyny. A Muslim man can have as many as four wives at a time, provided all are treated as equals. However, it seems that polygynous unions have been restricted to a small percentage of Muslims, namely the rich and the powerful.

With regard to the tribal population, we find that the customary law of the tribals in general (except a few) has not forbidden polygyny. Polygyny is more widespread among the tribes of north and central India.

- iii) **Polyandry:** Polyandry is even less common than polygyny. A few Kerala castes practised polyandry until recently. The Toda of the Nilgiris in Tamilnadu, the Khasa of Jaunsar Bawar in Dehradun district of Uttaranchal and some North Indian castes practise polyandry. In the fraternal form of polyandry, the husbands are brothers. In 1958, C.M. Abraham (1958: 107-8) has reported that in Central Travancore fraternal polyandry was practised by large number of groups like the Irava, Kaniyan, the Vellan and the Asari.

The factors that are related to the prevalence of polyandry are

- a) desire to prevent division of property within a family (especially in fraternal polyandry)
- b) desire to preserve the unity and solidarity of the sibling group (in fraternal polyandry)
- c) the need for more than one husband in a society where men are away on a commercial or military journey
- d) a difficult economy, especially an unfertile soil, which does not favour division of land and belongings (Peter 1968).

7.4.2 Prevailing Patterns

What is the position today regarding these forms of marriage? Monogamy is the most prevalent form of marriage in India. However, bigamous (having two spouses at a time) marriages have been reported among the Hindus in many parts of India. It is the man who very often commits bigamy and escapes punishment by turning the loopholes of the law to his advantage. It is the wife who is often unaware of his second marriage, and even if she is aware of it, is unaware of her legal rights and accepts her fate. Social and economic dependence on husband and inadequate social condemnation of the man's actions are some of the reasons for the wife's acceptance of the husband's second marriage.

Among the Muslims it is the man who is allowed to have four wives. Among them men enjoy greater privileges than women. A Muslim woman cannot marry a second time when her first husband is alive or if she has not been divorced by him.

Check Your Progress 1

- i) What is the legally prescribed age at marriage for boys and girls? Use one line for your answer.

.....

- ii) What are the three forms of marriage found in India? Use two lines for your answer.

.....

.....

7.5 PATTERNS OF SELECTION OF SPOUSE

There are three striking features regarding selection of spouse in India. Firstly the rules of endogamy, including those of hypergamy, indicate the groups into which a person is expected to find a spouse. Secondly, rules of exogamy, on the other hand, prohibit a person from marrying into certain groups. Both the rules of endogamy and exogamy are linked mainly to the caste and kinship structure. Thirdly, marriages in India are mostly arranged by the parents or elders.

7.5.1 Endogamy including the Rule of Hypergamy

We will first discuss the rule of endogamy and then show that the rule of hypergamy operates within the endogamous rules.

- i) **Endogamy:** The rule of endogamy requires an individual to marry within a specified or defined group of which he or she is a member. The group may be a caste, clan, racial, ethnic or religious group.

Religious and caste endogamy are two of the most pervasive forms of endogamy in India. Though legally permitted, inter-religious marriages are not commonly arranged or popular. In India there are innumerable castes which are divided into innumerable sub-castes which are further divided into subsections and each one of them is endogamous. The endogamous unit, for many Hindu sub-castes, consists of a series of kin clusters living in a fairly restricted geographical area. The operation of the rule of endogamy shows interesting variation by region and religion.

In South India, for instance, among many castes marriage with some relatives is preferred. In the Marathi, Telugu, Tamil and Kannada speaking areas, marriages with the cross-cousins (children of father’s sisters or mother’s brothers) are preferred. In North India, neither the parallel nor the cross-cousins can intermarry. In North India, on the other hand, there is a tendency to marry into villages that are not farther than twelve or thirteen kilometres from one’s village. Social and economic links are restricted to a few kin groups residing in certain areas. There are spatial as well as social boundaries which limit the field of marriage and these boundaries vary from region to region.

Endogamous rules are operative in non-Hindu sections of the population too. Among the Muslims, the ‘Syeds’, recognised as an aristocratic class, are divided into various endogamous groups. Sometimes the endogamous group

is so small that it includes only the extended families of a man's parents. Muslims permit marriages between both cross (mother's brother's children and father's sister's children) and parallel (mother's sister's children and father's brother's children) cousins. In fact, the father's brother's daughter is a preferred mate. Among Muslims the concept of purity of blood seems to be mainly responsible for preference of marriage between close relatives particularly between children of siblings. Many Muslim groups in North and Western India consider marriage between children of two brothers as most desirable. It is held that the desire to keep the family property within the family has been another important reason for close kin marriages. It is generally believed that marriage of the near kin helps to mitigate the conflict between a mother-in-law and daughter-in-law and this helps to strengthen the intra-as well as inter-familial ties.

- ii) **Hypergamy:** According to the rule of hypergamy, the status of the husband is always higher than that of the wife. Those who follow this rule always seek for their daughters those men who have social status higher than their own. It is a rule whereby marriage takes place or is generally arranged within a sub caste between a girl of a lower social status and a boy of a higher social status. This practice has occurred mainly among different subsections of a caste or sub caste rather than between castes. It is found that the tendency towards hypergamous stratification is available among all castes. Each caste is divided into several sub-castes, which are again divided into hierarchically ordered groups. It is quite clear that the rule of hypergamy operates within the confines of each endogamous group.

In ancient scriptures, it is given that *anuloma* marriages, based on the rule of hypergamy whereby a girl is married to a boy from upper caste sub-caste, were permitted. It is also given that *pratiloma* marriages, based on the rule of hypogamy, whereby a girl is married to a boy from a lower caste sub-caste, were not permitted. It would seem that in ancient times hypergamy (*anuloma*) across the four fold *varna* order was acceptable while hypogamy (*pratiloma*) was not permitted.

Practice of hypergamy has been found among such groups as the Rajput and the Jat of North India, Anavil Brahmin and Patidar of Gujarat, Maithil Brahmin of Bihar, Rarhi Brahmin of Bengal and among the Kanyakubja and Saryupari Brahmin of Uttar Pradesh to some extent. It has also been found among the Nayar, Kshatriya and Ambalavasi of Kerala.

The practice has shown a regional pattern. For instance, among the Rajput of Uttar Pradesh, traditionally girls were given in marriage from east to the west direction within a sub-caste. This is so because the Rajput clans were associated with a geographic region and a corresponding rating by region. Prestige of regions increased towards the westerly direction (Karve 1965: 165-171).

In the areas where hypergamy is practised, clans and lineages are of unequal status. Research (CSWI 1976: 65) has indicated that female infanticide among the Jat and Rajput was mainly a consequence of hypergamy. This was so because the girls of the highest groups had very little choice for marriage. Boys of their group could marry lower down while they had only the boys in groups which were at least equal to their own. Dowry has been generally high in hypergamous communities. Men from the Kulin subcaste of Bengal (belonging to the Rarhi Brahmin caste) often married many women at a time and demanded huge dowries.

This is so because they are ranked as the highest subcaste and women of this group have to be married within the group.

7.5.2 Exogamy

Exogamous rules are complementary to endogamous rules. These rules prohibit marriage between members of certain groups. The prohibition may be so narrow as to include those members within the elementary family (i.e. marriage between a brother and sister or parent and child) or so wide to include all those with whom genealogical kinship can be traced. The prohibition placed, on sexual intercourse between persons related in certain prohibited degrees of kinship is called incest, e.g., sexual relations or marriage between a brother and sister are defined as incestuous in most groups. The definitions of these groups, however, show variations mainly by region and religion. In North India, a girl born within a village is considered the daughter of the village and hence cannot marry a boy from her own village. Thus, the village becomes the exogamous unit here. In South India, the exogamous unit in one's own generation is defined by one's own sisters/brothers and real and classificatory parallel cousins.

Two other kinds of exogamy, which have been prevalent among several Hindu communities in North and South India, are *sagotra* and *sapinda* exogamy.

- i) **Sagotra exogamy:** In the context of the 'twice born' castes (belonging to the Brahmin, Kshatriya and Vaishya *varna* across) India *sagotra* exogamy applies to those who trace descent from a common ancestor, usually a *rishi* or a sage. All these people cannot intermarry. The term *gotra* is commonly used to mean an exogamous category within a *jati*. One of its principal uses is to regulate marriage alliance. All members of a *gotra* are supposed to be descendants of or associated with the same ancestral figure.

A four-clan rule or four *gotra* exogamous rule prevails among Hindu castes in North India. In accordance with this four clan (*gotra*) rule, a man cannot marry a girl from (i) his father's *gotra* or clan, (ii) his mother's *gotra* or clan, (iii) his *dadi*'s, i.e. his father's mother's *gotra* or clan, and (iv) his *nani*'s, i.e., his mother's mother's *gotra* or clan. In almost all castes in the northern zone, according to Karve (1953), the marriage between cousins is prohibited. We can show the four-clan rule in a diagram in the following manner.

The 1st cross in figure 7.1 indicates the marriage of ego to a person of ego's father's *gotra*. The 2nd cross indicates the marriage of ego to a person of ego's mother's *gotra*. The 3rd cross indicates the marriage of ego to a person of ego's paternal grandmother's (*dadi*'s) *gotra*. The 4th cross indicates the marriages of ego to a person of ego's maternal grandmother's (*nani*'s) *gotra*. All the four categories of marriage are prohibited among the Hindu castes in North India.

- ii) **Sapinda:** *Sapinda* exogamy indicates the prohibition placed on the inter-marriage between certain sets of relatives. *Sapinda* represents the relationship between the living member and their dead ancestors. The term *sapinda* means (i) those who share the particles of the same body (ii) people who are united by offering '*pinda*' or balls of cooked rice to the same dead ancestor. Hindu lawgivers do not give a uniform definition regarding the kinship groups within which marriage cannot take place. Some prohibit marriage of members within seven generations on the father's side and five generations of members from

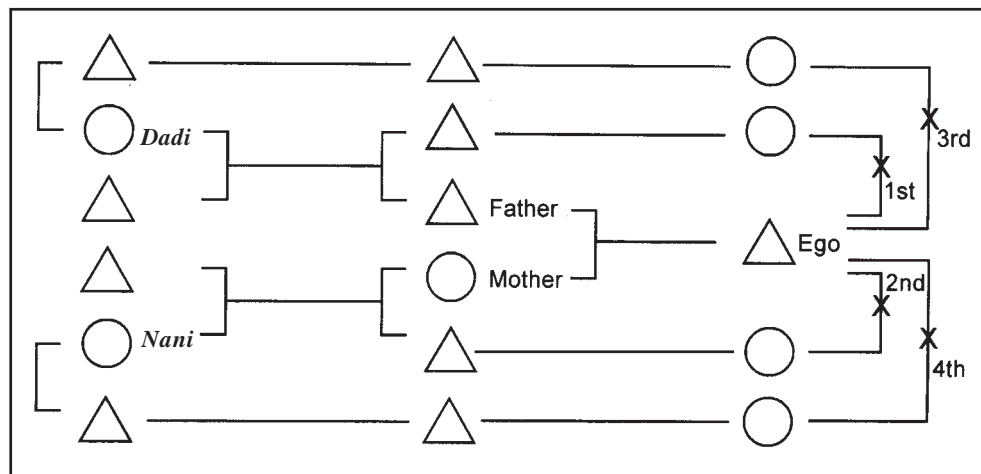

Fig.7.1: The four clan rule

the mother's side. Some others have restricted the prohibited generations to five on the father's and three on the mother's side. Several others have permitted the marriage of cross-cousins (marriage of a person with his father's sister's children or mother's brother's children).

The Hindu Marriage Act of 1955 does not allow marriage within five generations on the father's side and three on the mother's side. However, it permits the marriage of cross-cousins where this is customary. The patrilineal joint family is an important exogamous unit among Hindus. This much is quite clear from the fact that marriage is prohibited within five generations on the father's side.

Among Christians and Muslims, the elementary or nuclear family is the exogamous unit. Moplah Muslims of North Malabar in Kerala live in matrilineal units and among them matrilineage is the exogamous unit. Lineage exogamy also exists among the Muslim Gujjars of Jammu and Kashmir (Srinivas 1969: 56). Among the Nayars, who are a matrilineal group, a girl can never marry her mother's brother.

7.5.3 Arranged Marriages

Majority of the marriages in India are fixed or arranged by parents or elders on behalf of and/or with the consent of the boy or the girl involved in marriage. When marriage is fixed by parents or elders it is called an arranged marriage. This is in contrast to marriage by self choice (popular example of marriage by self choice is the so called "love marriage"). In some instances both these types of selection of one's spouse can be found together.

The prevalence of arranged marriages in India can be traced in relation to what has been said before, that is (i) existence of the rules of endogamy which limit marriage alliance within certain groups, (ii) the rules of exogamy which disallow marriage within *gotra*, (iii) regulations about prescriptive (allowing) and proscriptive (prohibiting) rules about marriage with parallel and cross-cousins and (iv) customs which indicate a specific preference for marriage between certain types of relatives or groups. All these factors make arranged marriages the most desirable form of selection of spouse. Choice of spouse cannot be left to the decision of the young if these restrictions and preferences are to be effectively carried out. The restrictions placed on free interaction between a boy and a girl in India is yet another factor which does not allow marriage by self choice.

Though the measure of participation in choosing one's life partner has shown variations between different groups, by and large, marriage arranged by parents/elders is the most prevalent form of selection of spouse. For majority of the high caste Hindus, matching of horoscope (charts relating to one's birth under certain astrological calculations) constitutes an important element in the final choice of the marriage partner. Today apart from astrologers matching the horoscopes of a boy and a girl, computers are also used to match horoscopes. Among the Muslims, the parents, elders or *wali* (guardian) arrange a marriage (Gazetteer of India 1965: 547 and CSWI 1974: 62).

7.5.4 Recent Trends

To what extent are the rules of endogamy, hypergamy, exogamy and arranged marriages operative today? Intercaste marriages are now recognised by law and take place on a larger scale than before. These intercaste marriages constitute only a very small proportion of the total number of marriages taking place. They are increasing at a slow rate. Caste endogamy is still highly relevant in the context of the patterns of selection of spouse. Many caste organisations devise all kinds of strategies to confine marriages within their castes and subcastes. There are even marriage "*melas*" (fairs) to ensure that the choice of the spouse is made within the particular subcaste.

Though majority of marriages continue to be arranged by parents/elders/*wali*, the pattern of choosing one's spouse has undergone some modifications today. We find the following patterns i) marriage by parents'/elders' choice without consulting either the boy or girl, ii) marriage by self-choice, iii) marriage by self-choice but with parents' consent, iv) marriage by parents' choice but with the consent of both the boy and the girl involved in the marriage, v) marriage by parents' choice but with the consent of only one of the two partners involved. Very often, the boy is consulted and his consent is taken. Parents/elders do not think it is important to ask the girl whether she approves the match. Among urban educated classes arranged marriage with the consent of the boy and the girl is often the most preferred pattern (Blumberg and Dwarki 1980: 139). Marriages are even arranged through newspaper advertisement for both the boy and the girl.

From this discussion of the patterns of selection of spouse, we now move on to marriage rites in India.

7.6 MARRIAGE RITES

Rites constitute an important part of marriage in India. We find variations in rites not only in terms of religion but also in terms of caste, sect and rural or urban residence. Let us look at some of the basic rites in a few communities in India.

7.6.1 Basic Rites of Marriage in Different Communities

For the Hindus, marriage is a **sacrament**. This means that a Hindu marriage cannot be dissolved. It is a union for life. This is also reflected in the marital rites. Some of the essential rites are *kanyadan* (the giving off of the bride to the groom by the father), *panigrahana* (the clasp of the bride's hand by the groom), *agniparinaya* (going around the sacred fire by the bride and the groom), *lajahoma* (offering of the parched grain to the sacrificial fire) and *saptapadi* (walking seven steps by the bride and the groom). These basic rituals are not confined to the

twice born castes (the Brahmin, Kshatriya and Vaishya) only, but these are also performed with some variations among other castes too. Some invite a Brahmin priest to recite the *mantra* which are religious invocations. The ritual of *kanyadan* is the most popular of all the basic rituals.

If we analyse the significance of the rituals of Hindu marriage we find that they stress male primacy and superiority (CSWI 1974: 64) and reflect the notion of transfer of the bride from her father's side to her husband's side. While emphasising life partnership for the two people involved in marriage, the basic rituals exhort the bride to follow the husband, to act according to his wishes and to remain steadfast in loyalty and love. In fact, marriage is the first major *samskara* (life cycle ritual) for a Hindu woman.

In some regions, among certain castes, the pre-marriage ritual is more elaborate than the actual wedding ceremony. For instance, among certain sections of the Nayar castes in Kerala, the actual marriage constitutes only the exchange of cloth between the bride and the groom, mutual garlanding and going around the lighted lamps. The pre-marital ritual of "*talikettu kalyanam*" is more elaborate than the actual marriage ceremony (Gazetteer of India 1965: 548).

Certain sections of the Jain community (like the Digambara and Svetambara) and the Sikh community have marriage customs and rituals which are similar to those of the Hindus. The core ceremony of the Sikhs however is different. It is called "*anand karaj*" and is solemnised in the presence of the Guru Granth Sahib, the holy book of the Sikhs. The main ceremony consists of the bridal couple going four times around the holy book. Appropriate verses, known as '*shabad*' are recited by the officiating priest. Unlike Hindus, Sikhs do not have any particular period or season for marriages.

Muslim marriage is not a sacrament. Rather, it is a contract, which can be terminated. Among the Muslims, the marriage rituals show variation by sect and region. Some rites of the Shia sect of the Muslims differ from the Sunni, a sect among the Muslims. However, the essential ceremony of Muslim marriage is known as the *nikah*. The ceremony is performed by the priest or the *kazi*. The *nikah* is considered to be complete only when the consent of both the groom and the bride has been obtained. A formal document known as *nikahnama* bears the signatures of the couple. Among certain sections, the signatures of two witnesses are also included in the document and the document may also contain details of the payment to be made to the bride by the groom. This payment is called the *mehr* which is a stipulated sum of money or other assets paid to the wife either immediately after the wedding or postponed till some future date.

Many of the marriage customs and rituals of the Muslims are similar to those of the Hindus. Thus, customs like smearing of turmeric (*Haldi*), applying *mehndi*, mock testing of the bride's proficiency at domestic work are as much a part of the Muslim marriage as Hindu marriage. In fact, among the Moplah Muslims of Kerala, the *nikah* ceremony is performed as laid down by Islam but their marriage is not regarded complete without the Hindu function '*kalyanam*'.

What is most significant to note in the rituals of Muslim marriage is that the custom of paying a *mehr* to the wife provides some sort of guarantee of security to the woman.

Among the Christians, the wedding takes place in a church. The exchange of the ring is an important ritual among them. Some sections of the Christians, like the Syrian Christians of Kerala, have the Hindu rite of the groom tying a ‘tali’ on the bride’s neck. Tali is a symbol of the married state of Hindu women in South India.

Among Christians, the following pronouncement, which forms a part of the marriage rites, reflects the importance assigned to the relationship of the husband and wife, rather than the relationship between the families of the husband and the wife. “Man shall leave his father and mother and shall cleave to his wife and they shall be one flesh.” This outlook emphasises the fact that marriage is a bond between two individuals and not between two families. It does not focus on the transfer of the girl from one family to another (CSWI 1974: 45).

As a part of marriage celebrations all communities hold wedding processions and feasts. Their scale may vary according to the socio-economic status of the bride and bridegroom’s families.

7.6.2 Customary Marriages

While rites constitute an important component of marriage among many communities, there are sections or groups of people who do not have religious rites in marriage. Marriages with no rites are referred as customary marriages. These marriages are based on simple practices. For instance, in some groups living in the Himalayan tract, putting a ring in the bride’s nose is a customary form of marriage. Customary forms of marriage are generally found among those groups where divorce and secondary marriages are permitted and practised. Secondary marriage of a widow or a separated or divorced woman is usually celebrated in a simple way, which indicates essentially the renewal of her married state (CSWI 1974: 83).

Today marriage rites have been condensed to a great extent. The Special Marriage Act of 1954 provides for secular and civil marriage before a registrar. This Act applies to all Indian citizens who chose to make use of its provisions, irrespective of religious affiliations. Civil marriage enables persons to avoid the expense of traditional weddings. However, weddings continue to be an expensive affair for a large majority of people. Large sums of money, gifts of jewellery, furniture, vessels, clothes have to be bought and generally the expenses are more for the bride’s side than the groom’s side. This discussion takes us to the next topic of the transfer of goods and prestige that accompany marriage in India.

Check Your Progress 2

- i) Define (a) endogamy (b) exogamy and (c) hypergamy. Answer in ten lines.

.....

.....

.....

.....

.....

.....

.....

-
-
-
- ii) What is the main feature of a customary marriage? Answer in one line.
-

7.7 THE TRANSFER OF WEALTH AND PRESTIGE THAT ACCOMPANY MARRIAGE

Marriage, in most cases, involves material as well as non-material transactions between the bride-giver and the bride-taker. It involves, with a few exceptions, the transfer of the wife to the husband's family.

Two major types of transfers of material wealth accompany marriage. In one, wealth travels in the opposite direction of the bride and in another it travels along with the bride in the same direction. The former is identified as bride price while the latter as dowry (CSWI 1974:69).

7.7.1 Bride-Price

The tradition of bride-price is found among certain patrilineal tribes and some castes in the middle and lower rung of the caste ladder. The form and amount of bride-price vary from region to region, from tribe to tribe and within a tribe from time to time. Some pay only cash, some others only in kind while some pay both in kind and cash. Payment in kind includes a wide variety of things like clothes, ornaments, tools and implements, liquor, grain, cattle, goats and other forms of livestock. For instance, among the Uraon tribe of Chotanagpur a man takes sets of clothes for the bride's relatives. Bhumias of Orissa give cash, five or six sarees and three goats as bride-price (CSWI 1974: 69). Bargaining for bride-price is also common. In some tribes, the groom offers his services to the bride's father as a form of bride-price.

Under the local influence of high caste values and practices, some groups have given up their custom of bride-price and have adopted the custom of dowry. For example, the peasants of the villages of Karnataka and the Godia (or the cowherds) caste in Andhra Pradesh have given up their custom of bride-price and adopted the custom of dowry (CSWI 1974:70).

Bride-price or the payment in cash and/or kind to the bride's father by the groom's father reflects the transfer of authority over the bride from her father to the groom and his family. The idea of compensation for the loss of a productive worker is also implicit in it. The bride's family loses a productive worker when the girl gets married and leaves her parental home. So, the bride's family is paid a compensation for this loss (CSWI 1974: 69-72). The girl is a source of wealth and prestige to her natal family, that is the family in which she is born. In this sense, the transaction implies the transfer of all that the girl stands for. Now, let us look at another form of transaction of wealth and prestige that accompany marriage in India.

7.7.2 Practice of Dowry

Broadly speaking, dowry refers to a specific category of gifts given by the bride's side to the groom's side. This set of gifts symbolises the transfer of wealth from the bride's side to the groom's side. This act confers prestige and honour to both the sides. The bride-giver gains prestige within his community by giving dowry while the bride-taker receives both wealth and prestige in his own and other communities. Of late it has become groom-price.

Today, in legal terms, dowry constitutes what is given to the son-in-law and or to his parents on demand either in cash or in kind by the bride's side. There are, of course, regional variations in the practice and people's understanding of the term 'dowry'. Some view it mainly as 'groom-price' and often the price paid to the groom depends on the groom's qualifications, job, social status regardless of the bride's parents' ability to pay the price demanded by the groom's side. Some include in the custom of dowry i) what is given to the bride during and after the wedding, during occasions like festivals, child birth, initiation etc. in the first few years of marriage ii) what is given to the bridegroom before or after marriage and iii) what is presented to the in-laws of the girl.

Here, we need to note that (a) dowry constitutes an array of gifts given to the groom's side over time and (b) what is given at the time of the wedding is substantial and conspicuous. Goods that constitute dowry are i) movable property like sarees, jewels, silver vessels, cash, vehicles like car, tractor and ii) immovable property such as land, house, factories, jobs etc.

The form and amount of dowry and purpose to which dowry is put have shown variations based on caste, class, region and socio-economic status. Among the landowning castes of Andhra Pradesh (like Reddy, Kamma) a father may give to his daughter land and jewellery. The cash may be handed over to the groom or his parents but the land is registered in the name of the daughter. Money also is deposited in the name of the bride or put in trust for her. In North India, where there has been a tradition of giving large utensils to the girl, the utensils generally come under the use and control of the in-laws. The amount of cash involved in dowry varies mainly according to the socio-economic status and expectations of the groom's community as well as the socio-economic status of the bride's family. Again, the gift in cash or in kind involved in dowry may be put to productive purposes or just hoarded as wealth by the bride, the groom and/or his family (CSWI 1974: 70-72).

The practice of giving gift to the girl at the time of and after the wedding has been viewed as *streedhana*. This means that the gifts given to the daughter are a kind of property given to the daughter of the house who has to leave her natal home to join her husband. *Streedhana* reflects the notion of female right to property (CSWI 1974: 70 72). It is looked as a source of wealth for the married daughter to fall back in times of crisis and need. In many regions of South India, the gifts (ornaments, vessels) given to the daughter belong to her exclusively and she has the right to use them the way she wants. Her in-laws generally do not claim possession over them.

Today, the practice of dowry has taken a very ugly turn. As mentioned in section 7.3.2, in many instances, the practice of dowry has worsened. Educated girls look out for boys who are more qualified than them. Highly qualified boys demand

a high dowry. As a result of increase in dowry demand, parents often are unable to get their daughters married. If they do, they get them married beyond their means and are subject to different kinds of continuing pressures in the form of dowry demands from the groom's side. We often hear of dowry deaths or the girl being sent back to her parents' home for not fulfilling the dowry demands. Today, we even hear cases of unmarried girls committing suicide in order to ease the burden of their anxious, guilt-ridden parents, who have not been able to settle a marriage for them.

In 1961, the Government of India passed the Dowry Prohibition Act. In 1984 and again in 1986, the Act was amended to make the law more stringent and effective. For instance, today, the husband and his family can be penalised for demanding dowry if his bride dies within seven years of the marriage in other than normal circumstance. We even have a Dowry Prohibition Cell to look into complaints about dowry.

All this does not mean that there are no marriages taking place without dowry. There are progressive young people who voice their strong opinion against dowry and marry without it. There are at the same time, young, educated people who accept this practice and say they see no harm in it. Some get away by saying that it is their parents (whose wishes they never want to disobey) who perpetuate this practice. Even among other communities, like the Muslim and Christian, some people demand dowry. Often, discord in family is caused because of the continuous demand for dowry even after marriage. This may lead to divorce. Let us look at the issues of divorce and remarriage in India.

Activity 2

Take newspapers of a week. Read the columns, which have reported about dowry. The newspaper can be an English daily or in any other regional language. Then, write a note on the nature of reporting of such issues in the newspapers. Compare your note with those written by other students at your study center.

7.8 DIVORCE AND WIDOW REMARRIAGE

No discussion of marriage is complete without considering the issues of divorce and remarriage. Here, we look first at the possibilities and mechanism of dissolving a marriage and then discuss briefly the question of widow remarriage in India.

a) Divorce

The possibilities and mechanisms of dissolving a marital union have varied through time, between and within communities. Hindu marriage is in theory a sacrament and irrevocable. However, among many *non-dwija* (or non-twice born) castes, divorce is customarily allowed. When we say non-twice born castes, we mean those castes, which do not observe the practice of performing the life-cycle rituals or Hindu *Samskara*. Their performance symbolises the second birth or social birth of a biological person and hence the term twice-born for the first three categories of Hindu castes—the Brahmin, Kshatriya and Vaishya, which must and do perform these rituals. The notion that marriage is indissoluble has gradually been eroded and through legislation, the right of divorce has been introduced in all legal systems in India.

The grounds for divorce have been spelt out both by custom and by law in different communities. During 1940-48, several provinces and states passed laws permitting divorce for Hindus. The Special Marriage Act of 1954 introduced and 'clarified the grounds for divorce'. It has been available to all Indians who have chosen to register their marriages under this Act. The Hindu Marriage Act of 1955 was amended several times since 1955 (the next one being in 1976) to incorporate a wide range of grounds for divorce available to both men and women coming under the purview of this Act. Some of the important grounds for divorce outlined by law are i) impotency, ii) lunacy (for a specified time period), iii) disappearance for seven years, iv) contagious disease, v) rape, vi) homo-sexuality, and vii) bestiality (sexual relationship between a human being and a lower animal). Now adultery and cruelty have also become the grounds on which divorce may be sought. The condition that one can apply for divorce after three years of marriage has been reduced to one year. The waiting period of divorce by mutual consent is now only 6 months.

Among the Muslims, marriage is a contract and divorce is allowed. Muslim law provides for different types of divorce of which *talaq* and *khol* need special mention. *Talaq* is an exjudicial divorce. It becomes effective if pronounced thrice unilaterally by the husband. It signifies the power the husband has to divorce his wife at will. The other form of divorce *khol* takes place by mutual consent.

Public attitude to divorce in a Hindu dominated culture is not yet very liberal in spite of the legal permission for divorce. In many communities of the Indian population, divorce even when it is required is not sought, despite legal provisions. Even in cases where women have turned to the legal system for help, law is not very clear about the rights of a woman in her marriage. For instance, the respective judgments of Andhra Pradesh High Court and Punjab High Court in two cases relating to the Hindu woman's right in the matter of being a wife or a mother reflect the ambiguity. In one case in Andhra Pradesh the judgment favoured the woman. Her right to decide whether she wanted to bear the child of the husband whom she did not find compatible was upheld. In the other case in Punjab, the wife was held guilty for refusing to bear a child by her spouse whom she did not find compatible. Women activists point out that though our constitution supports the notion of equality between sexes, the laws passed to promote such a notion have not been able to end the discrimination shown toward women. Even among the Muslims, where divorce has been permitted for a long time, laws favour men more than the women (Ghosh 1984).

b) Widow Remarriage

Certain sections of the Indian population have a tradition of widow remarriage. Levirate alliances have been reported among the Ahirs of Haryana, some Jats and Girjans and several castes in U.P. and among the Kodagu of Mysore (Gazetteer of India 1965: 541). In a levirate marriage, a man is obliged to marry the widow of a brother.

In many castes of the Hindu fold, widow remarriage has been customarily sanctioned and practised. Only those castes which imitate the life-style and values of the high castes adopt the practice of banning widow remarriage. Widow remarriage is permitted among the Muslims, Christians and Parsis. Among the Jains local and caste customs determine the issue.

Generally, everywhere the widower has the right to remarry. The 1971 census of India showed that there were 8 million widowers as against 23 million widows (CSWI 1974: 77). In the year 1991, among the elderly (60+ age group) the percentage of widows was 60.7 and that of widowers was 19 (Census of India 1991). It is often said that the problem of widow remarriage is the problem only of a section of society because only the high castes put a strict ban on widow remarriage. Not only this, in the past, widows of some priestly castes, royal families were also expected to commit the practice of sati or widow burning. The practice of widow burning comprises self-immolation of the widow on the funeral pyre of her husband. Respect is paid to such women who end their lives as a mark of devotion to their husbands.

As early as in the nineteenth century, reformers like Vidyasagar, fought against the practice of sati and exploitation of widows. In 1856, the Hindu Widows Remarriage Act legalised the marriage of widows of all castes. Traditional notions about widow remarriage and the treatment of widows still seem to be prevalent. Widows are still regarded as inauspicious; they are not expected or permitted to participate in certain religious and social functions. It is shocking to hear that widows are still burnt alive on their husband's pyre and there is a section of the population, which glorifies such act. The most recent case of law being enacted to protect the woman victim is the law against the practice of widow burning or sati. This was passed by the Parliament in response to a national demand and reaction following the burning of a young educated woman, Roop Kanwar, on the funeral pyre of her husband in Deorala, a village in Rajasthan. The Act is called Commission of Sati (Prevention) Act, 1987.

Check Your Progress 3

- i) What are the two major types of the transfer of material wealth that accompany marriage? Answer in four lines.
.....
.....
.....
.....
- ii) Write T for true and F for false against the following statements.
 - a) Dowry is punishable by law.
 - b) *Talaq* and *Khol* are the two types of divorce available to Muslims.
 - c) Muslims, Christians and Parsis do not permit widow remarriage.

7.9 LET US SUM UP

We began with the two strikingly common features of marriage in India. Namely, that almost everyone marries and that the age of marriage is low in India. We then moved on to the diversity in its patterns. We discussed three different forms namely monogamy, polygyny and polyandry, and about the patterns of selection of spouse. In this context we spoke of endogamy, hypergamy and exogamy. Then we said that though marriages are mostly arranged in India, today it is possible to find

other methods of selecting one's spouse. Rites constitute an important part of marriage in every community. We outlined the differences in this area by illustrating them from a few communities like the Hindus, Muslims and Christians. Then we discussed the transfer of wealth and prestige that accompany marriage. In the last section on divorce and remarriage we discussed these issues with reference to major communities. While discussing each of these aspects, we took note of the important legislations and other factors, which have had an impact on the institution of marriage in India.

7.10 KEYWORDS

Anuloma	Marriage between a man of higher social position and a woman of lower social position is called anuloma ("with the hair") and is, within certain limits, approved
Monogamy	A form of marriage in which a person is married to one person at a time
Polyandry	A form of marriage in which a woman is married to two or more men at a time
Polygyny	A form of marriage in which a man is married to two or more women at a time
Pratiloma	A woman marrying beneath her social position is called <i>pratiloma</i> (against the hair) and is strongly disapproved
Rites	Prescribed and established forms of ceremony
Sacrament	A formal religious act that is sacred as a symbol .of spiritual reality
Sagotra	People belonging to the same <i>gotra</i> or a clan

7.11 FURTHER READING

Ahmad, Imtiaz (ed.) 1976. *Family, Kinship and Marriage Among Muslims in India*. Manohar: New Delhi.

Augustine. J.S. (ed.) 1982. *The Indian Family in Transition*. Vikas Publishing House: New Delhi

CSWI (Committee on the Status of Women in India) 1974. *Towards Equality*. Department of Social Welfare, Government of India: New Delhi

Kapadia, K.M. 1972. *Marriage and Family in India*. Oxford University Press: Bombay

Jain, Shobhita 1996a. *Bhart mein Parivar; Vivah aur Natedari*. Rawat Publishers: Jaipur.

Karve, Irawati 1994. The Kinship Map of India. In Patricia Uberoi (ed.) *Family, Kinship and Marriage in India*. Oxford University Press: New Delhi

7.12 SPECIMEN ANSWERS TO CHECK YOUR PROGRESS

Check Your Progress 1

- i) 21 years for boys and 18 years for girls.
- ii) The three forms are monogamy, polygyny and polyandry.

Check Your Progress 2

- i)
 - a) Endogamy: A rule of marriage whereby an individual is required to marry within a specified group of which he/she is a member.
 - b) Exogamy: A rule of marriage whereby an individual is required to marry outside the group of which he/she is a member.
 - c) Hypergamy: A rule of marriage whereby a girl is married to a boy whose social status is higher than her own. It occurs mainly among different subsections of a caste/subcaste rather than between castes.
- ii) Customary marriages do not involve rites.

Check Your Progress 3

- i) The two types of transfer of material wealth that accompany marriage are bride-price where wealth travels in the opposite direction of the bride and dowry in which wealth travels along with the bride, towards the groom.
- iii)
 - a) True
 - b) True
 - c) False